

# Dialight

## 860 CASA

### LED OBSTRUCTION LIGHT



CASA Part 139 Sect 9.4 Compliant

#### FEATURES / BENEFITS

- ▲ Unique optically designed lens to enhance LED operation and provide 360° visibility
- ▲ State-of-the-art high-flux LED technology
- ▲ Lasts years longer than an incandescent
- ▲ Weather/corrosion resistant lamp assembly and housing
- ▲ Self-contained wiring compartment eliminates additional boxes
- ▲ Threaded 1" and 3/4" bottom hub for mounting
- ▲ Can be flashed or steady burned (controller not supplied)
- ▲ 5 year warranty
- ▲ Resistant to shock and vibration
- ▲ 50cd or 100cd

US PATENT# 6,425,678

#### APPLICATION

- ▲ Designed for steady burning, this fixture is used to mark any obstacle that may present hazards to aircraft navigation. The US patent office has issued patent number 6,425,678 B1 for this series.

#### SPECIFICATIONS

- ▲ Operating Conditions:  
Temperature: -67°F to +131°F (-55°C to +55°C)
- ▲ Finish: Cast Aluminum with Stainless Steel Hardware
- ▲ Approximate Shipping Weight: 7.4 kg double  
Container Dimensions: 560mm x 430mm x 230mm double
- ▲ Photometric: Minimum Intensity: 100 candelas between 6° and 10° above the Horizontal Axis
- ▲ Operating Voltage (VAC) 50Hz:  
Min. 198 Nom. 230 Max. 265
- ▲ Watts (at Nom. Input Voltage): Min. 24 Typ. 28 Max. 34
- ▲ Part Numbers: **860-7R02-001 (Single Unit)**  
**860-7R02-002 (Dual Unit)**



Single Unit

## PRELIMINARY

Dialight reserves the right to make changes at any time in order to supply the best product possible.

#### Dialight Europe Ltd.

Exning Road, Newmarket, England, CB8 0AX  
Tel: +44 (0) 1638 666541 • Fax: +44 (0) 1638 561735  
www.dialight-obstruction-lights.com  
A Subsidiary of Dialight PLC



#### Dialight Corporation

1501 Route 34 South • Farmingdale, NJ 07727 USA  
Tel: (1) 732-919-3119 • Fax: (1) 732-751-5778  
www.dialight.com



MDTF860XCASA\_1

## MECHANICAL DIMENSIONS

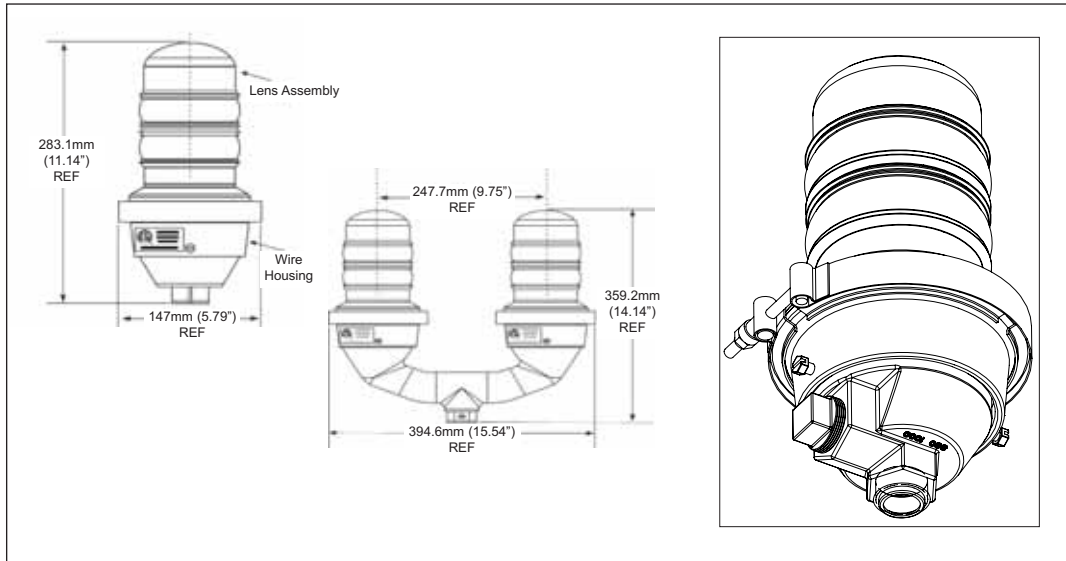

## MECHANICAL DIMENSIONS

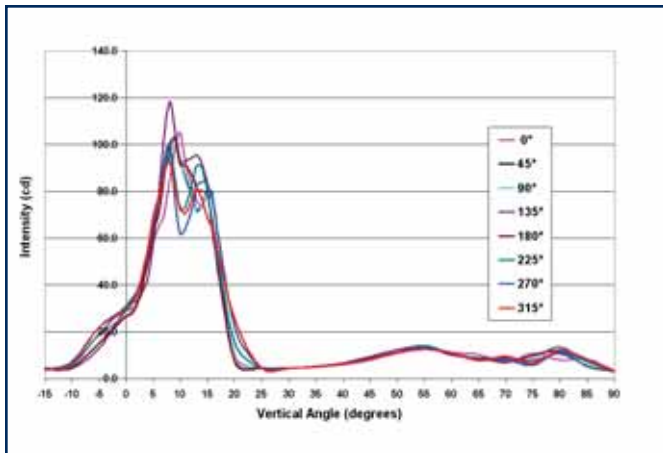

50 cd

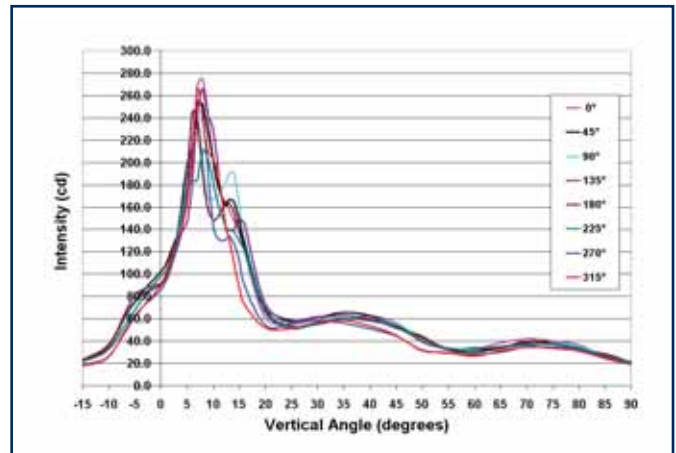

100 cd

## PRELIMINARY

Dialight reserves the right to make changes at any time in order to supply the best product possible.

### Dialight Europe Ltd.

Exning Road, Newmarket, England, CB8 0AX  
 Tel: +44 (0) 1638 666541 • Fax: +44 (0) 1638 561735  
[www.dialight-obstruction-lights.com](http://www.dialight-obstruction-lights.com)  
 A Subsidiary of Dialight PLC



### Dialight Corporation

1501 Route 34 South • Farmingdale, NJ 07727 USA  
 Tel: (1) 732-919-3119 • Fax: (1) 732-751-5778  
[www.dialight.com](http://www.dialight.com)



MDTF860XCASA\_1